

2

1

Parts List

ITEM	QTY	PART NUMB	DESCRIPTION	PROCESS	MATERIAL	REV #
1	7	21014	Lockers - Plastic Sleeve	Saw	ABS Plastic	0
2	7	21025	Lockers - Pivot Assy	Weld / Assy / Galv	As BOM	2
3	1	21113	Lockers - 15ft / 8 Stall Section - Welded Assembly	Weld / Assy / Galv	As BOM	3
4	14	21277	Self Locking Flipper	Laser/Form/Galv	Steel, Mild	0
5	1	21284	Lockers - Round Operator Bar	Saw / Swage / Punch / Galv	Tube 26.7mm OD	2
6	2	102433	Bolt-M6 x 55 Gr8.8 Pltd		8.8	
7	7	107299	Bolt-Carriage 8mmx65mm Plated Gr.2 Metric		Default	0
8	14	107302	Locknut - 8mm Nylon Metric Plated		-	
9	16	107303	Locknut - 6mm Nylon Metric Plated		-	
10	7	107304	Bolt-Carriage 8mmx75mm Plated Gr.2 Metric		Default	0
11	14	107618	Bolt-Carriage 6mmx45mm Plated Gr.2 Metric		Default	0

B

B

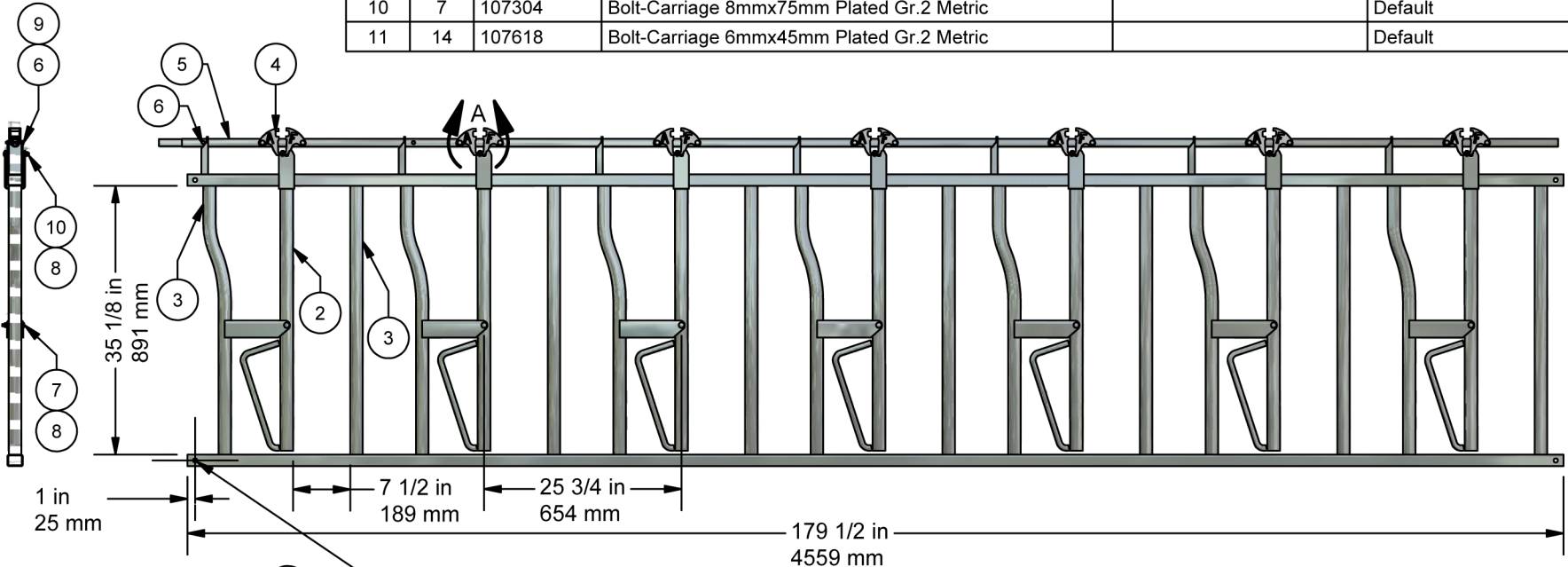

A

A

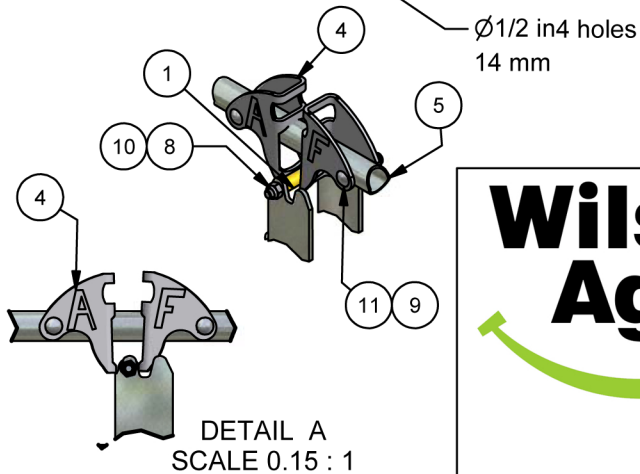

REVISION HISTORY		
REV	DESCRIPTION	DATE
1	Item 2177 replaced old 21027/ 107301 replaced 107618/ Lock Up bolts (item 6) added/ Some assembly dimensions revised.	8/10/2007
2	Number of openings reduced to 7/ Some assembly dimensions and components changed	8/15/2007

Date	Name	W.O	Cattle Handling		
Des. By	2/14/2007	msafa	W.O		
Dw. By	8/15/2007	msafa	Material		
Ch. By			Process		
App. By			WELD ASSY		
			Tolerance = ± 1/16"		
			Self Lockers-15ft / 7 Stall		
			DWG.No.	Sheet	Rev
			21091.idw	1	2
			File Path		
			N:\Drawings\20,000-29,999 - Cattle Handling\21000 to 21999\21091.idw		

2

1